

B-B (1:25)

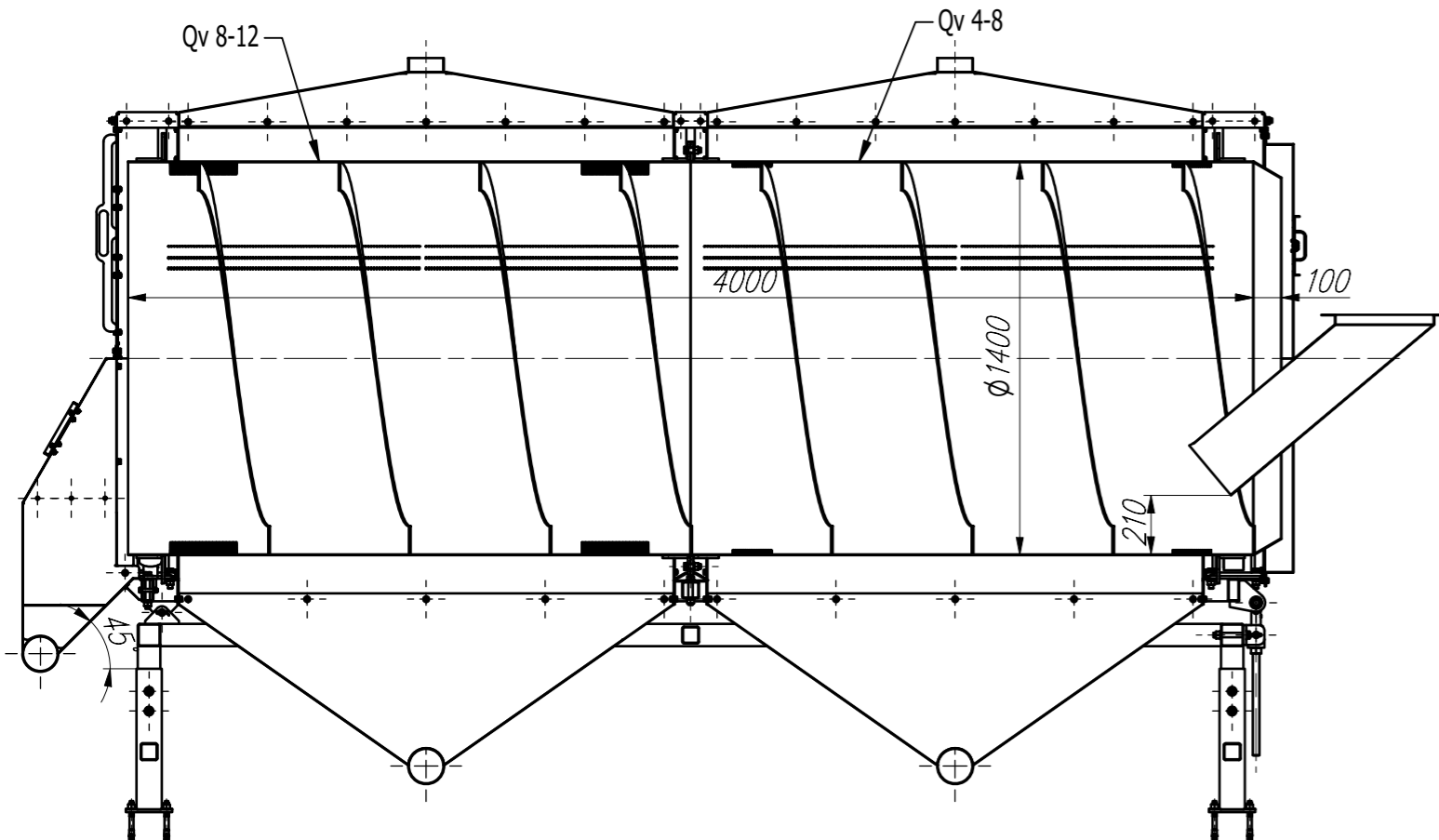

<p>GET MORE FROM MACHINERY</p> <p><small>Niniejsza dokumentacja i prawa jej rozpowszechnienia stanowią własność i bez pisemnej zgody nie może być używana lub kopiowana tak w całości jak i częściowo.</small></p>	Konstruował	DK	KK	09.08.2021
	Sprawdził	DK		09.08.2021
	Zatwierdził	DK		09.08.2021
	Numer rysunku:			
PBO-1400-4000-00-100				Format
Nazwa rysunku:				A2
Przesiewacz bębnowy				
Podziałka	Masa [kg]	Materiał		
1 : 22	1506,6 kg			

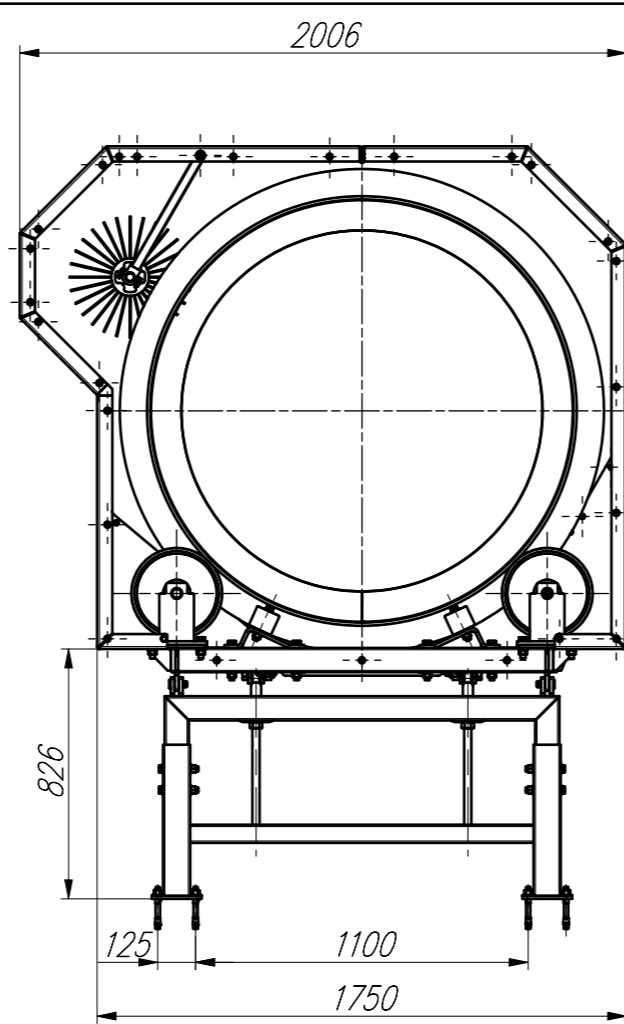

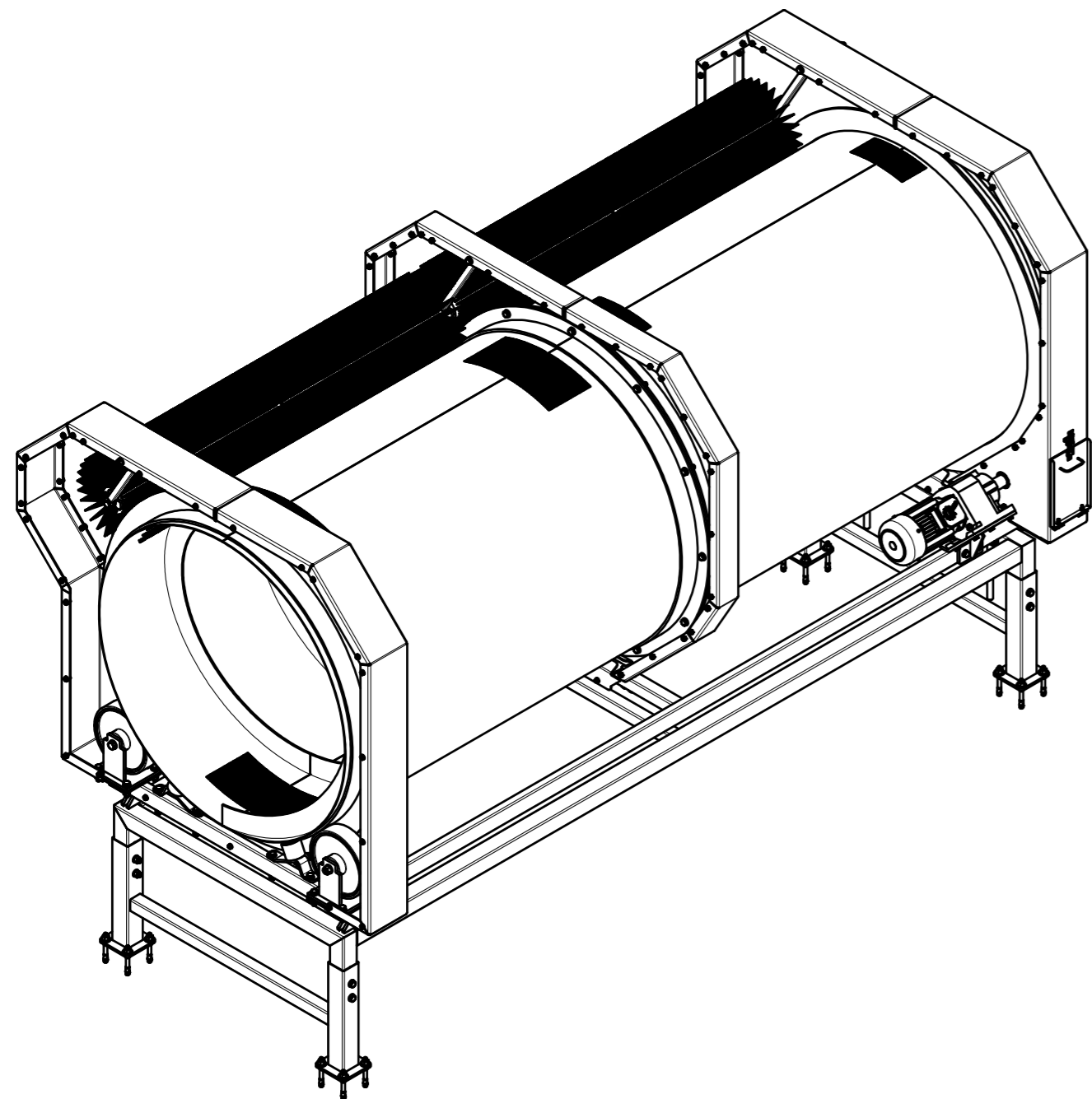
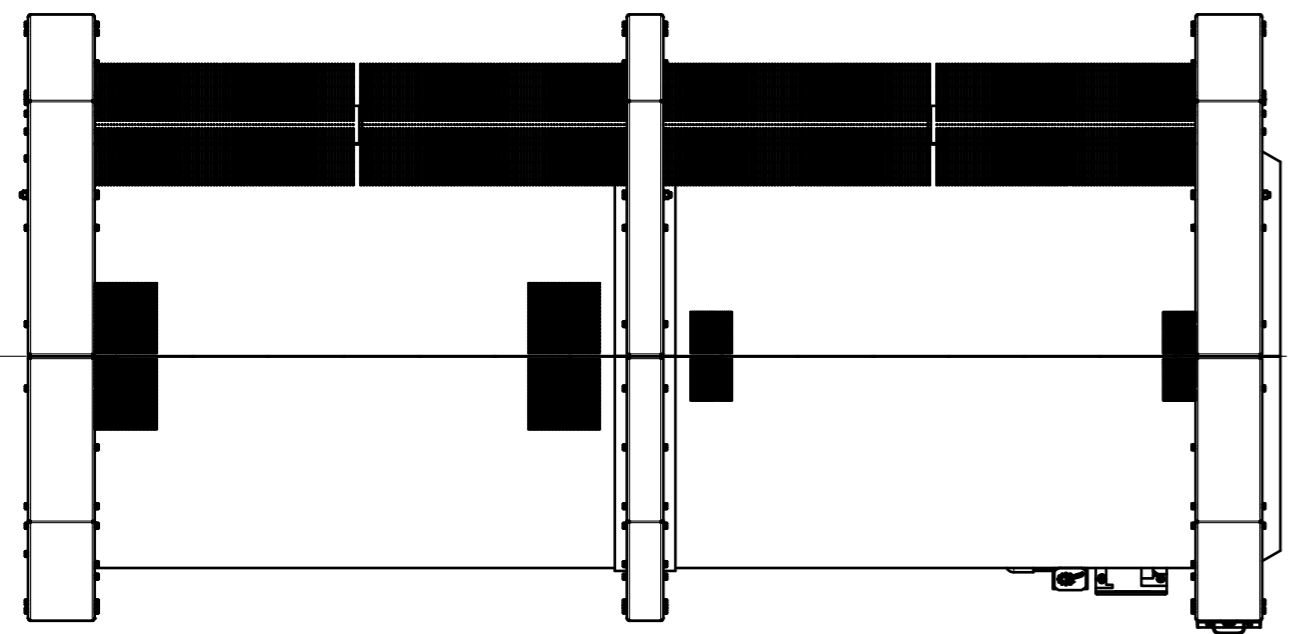
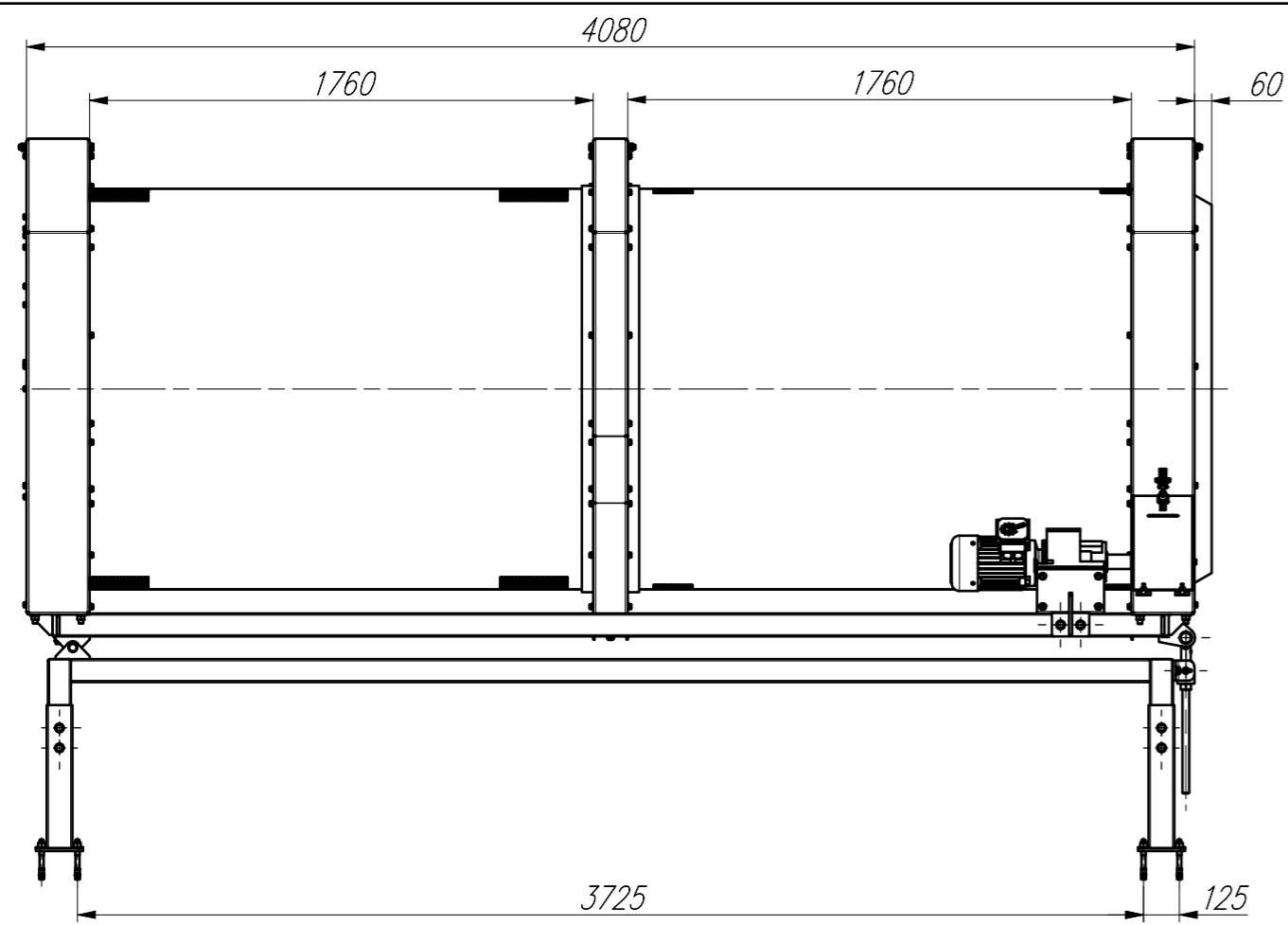

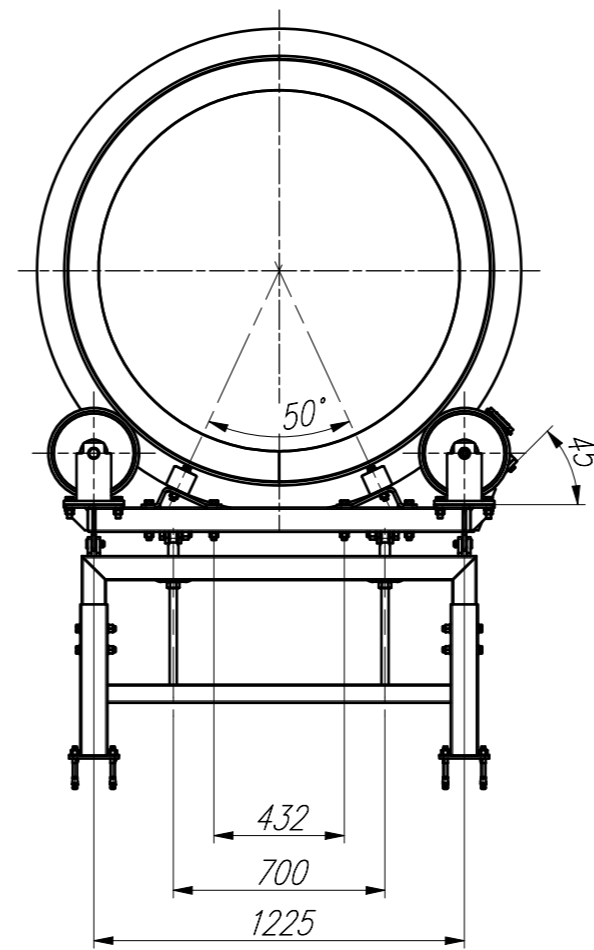
Widok bez osłon

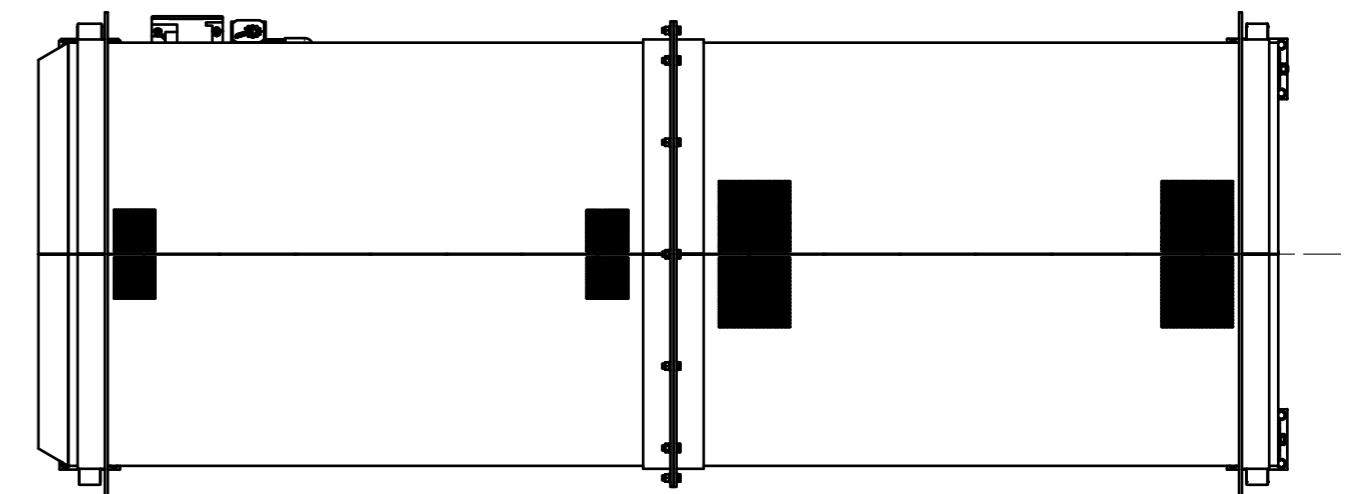
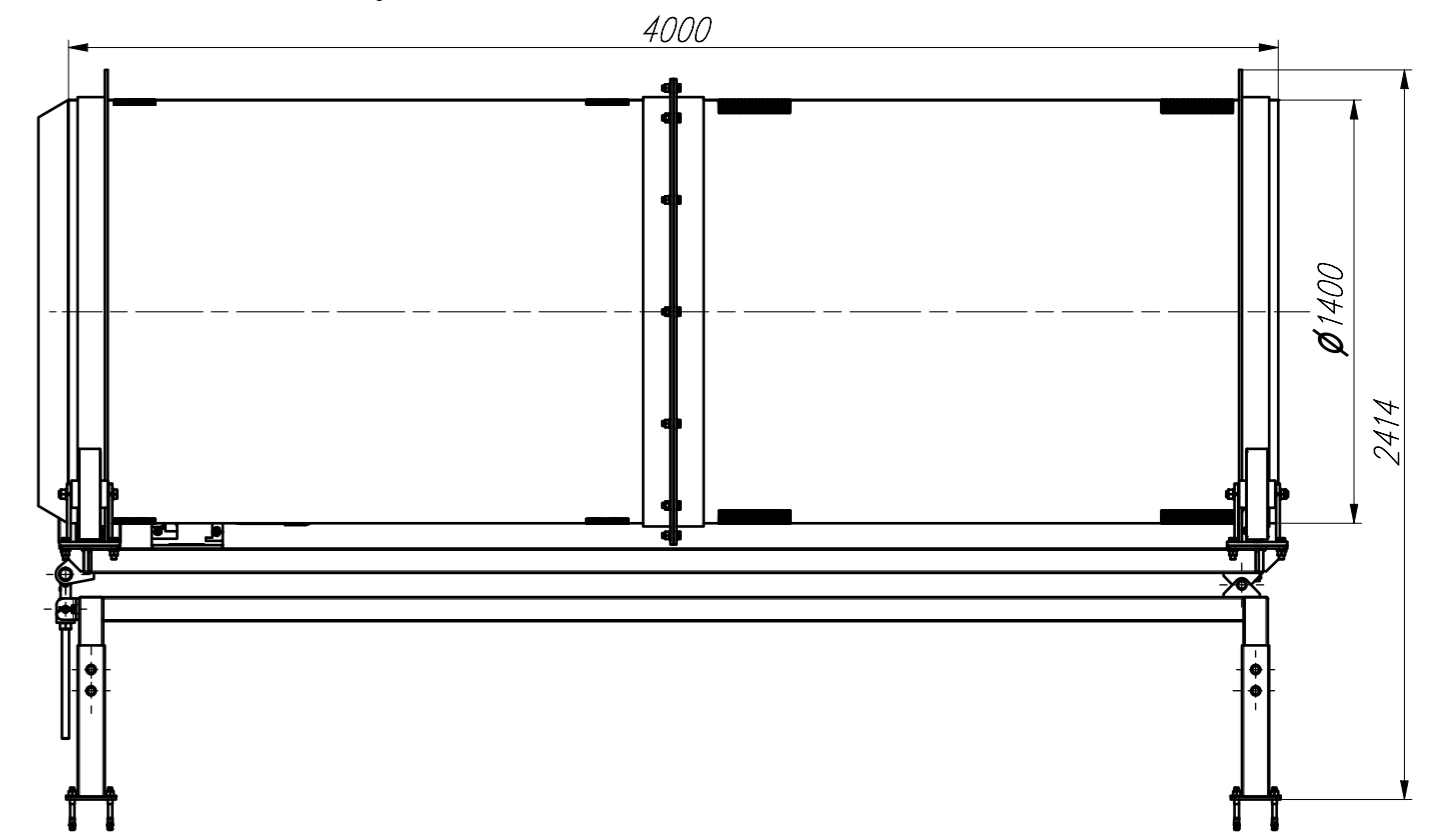
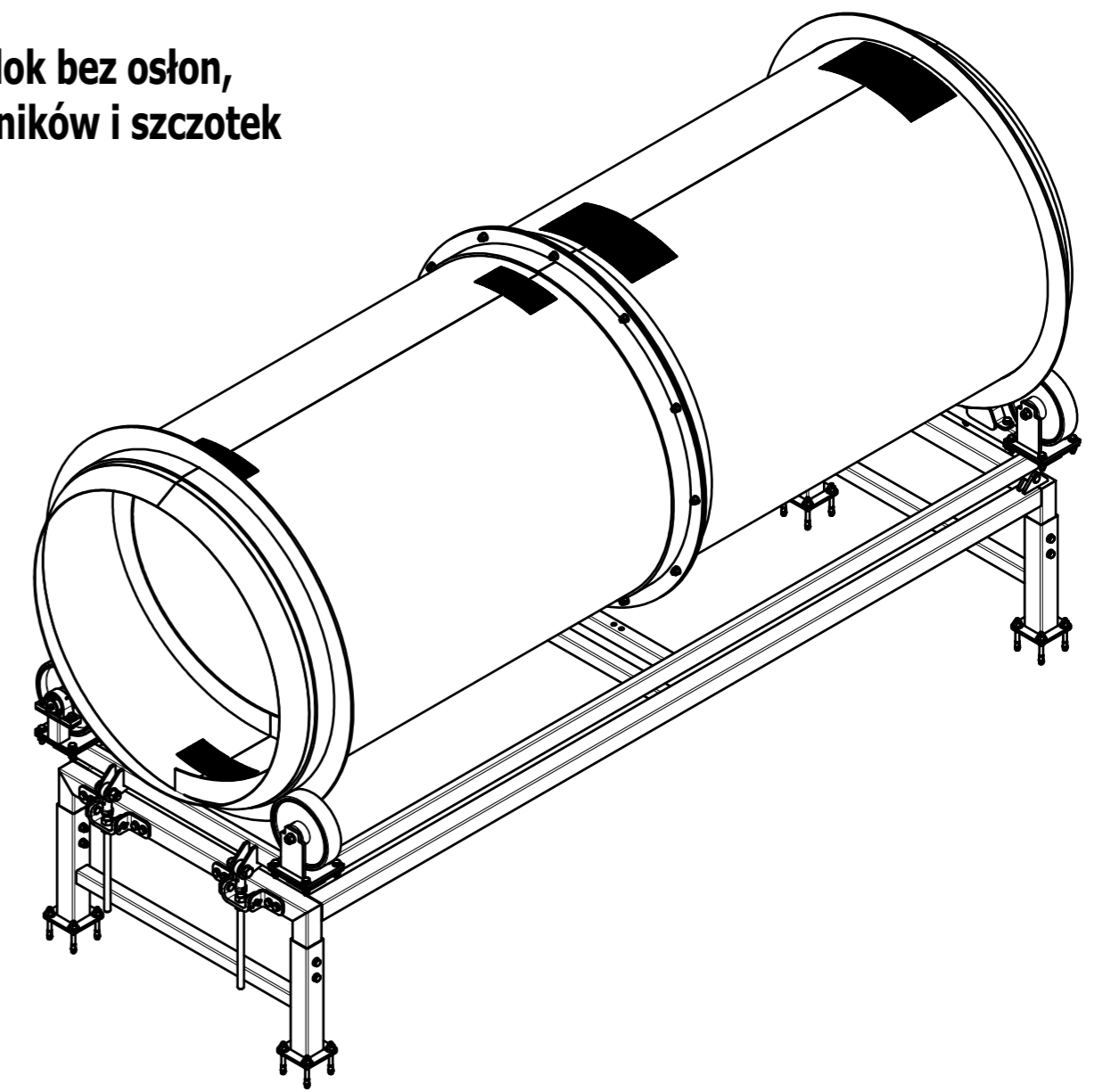

Widok bez osłon,
wsporników i szczotek



 <small>Niniejsza dokumentacja i prawa jej rozpowszechnienia stanowią własność i bez pisemnej zgody nie może być używana lub kopiowana tak w całości jak i częściowo.</small>	Konstruował	DK	KK	09.08.2021
	Sprawdził	DK		09.08.2021
	Zatwierdził	DK		09.08.2021
	Numer rysunku:			
PBO-1400-4000-00-100			Ilość ark. 2/2	
Nazwa rysunku:			Format	A2
Przesiewacz bębnowy				
Podziałka	Masa [kg]	Materiał		
1 : 25	1506,6 kg			